



# POWRMATIC®

Delivering complete climate control solutions worldwide

Indirect oil fired heating solution with advanced high/low burners combining form, function and ErP compliance.

**The Powrmatic OUH.**

# OUH

Suspended Oil Unit Heater

Oil Fired Options



[www.powrmatic.co.uk](http://www.powrmatic.co.uk)

# OUH Suspended Oil Unit Heater



## ErP Compliance

As from September 2018 the scope of the current Ecodesign regulation (EU) 2015/1188, Directive 2009/125/EC - Lot 21 Tier 1 (ErP) regulation is widened to embrace maximum levels of Nitrous Oxide (NOx) emissions.

All warm air heaters used to provide comfort for the occupants of a heated space must emit NOx levels less than 100 mg/kWh. Compliance to the standard remains mandatory.

## Product Benefits



REDUCED NOx TECHNOLOGY



EASY INSTALLER MAINTENANCE



35 & 28 SECOND OIL FIRED OPTIONS



COMPACT DESIGN



PROVEN DESIGN

The OUH range of Oil Unit Heaters are indirect oil fired suspended warm air heaters with a stainless steel heat exchanger as standard and a downwards high/low firing pressure jet oil burner.

The OUH heater can be supplied in axial fan freeblowing format, to be installed directly into the space to be heated, or with centrifugal fan for ducted applications. The OUH range of oil fired unit heaters is comprised of 4 models with outputs ranging from 20kW to 60kW.

The range has been designed for use in factory or warehouse premises where oil firing is a requirement and floor space is at a premium.

### Models Available Heading

- OUH F - Freeblowing Oil Unit Heater
- OUH C - Centrifugal Oil Unit Heater
- OUH D - Ducted Oil Unit Heater

# Compact Proven Compliant

The OUH From Powrmatic

## Product Features

### Reduced NOx Levels

The latest ErP regulations demand reduced NOx and increased seasonal efficiency, OUH meets these standards by utilising state of the art burners, air movement and control technology whilst maintaining the temperature rises required in cabinet heater installations.

### Proven Product Design

The proven design and years of longevity make the OUH a leading recommendation for the HVAC installer. With simply maintenance access and ease of installation, the OUH is the perfect heating solution for buildings with oil only available.

### Heat Exchanger

The robust and proven heat exchanger is manufactured as standard from 304 grade stainless steel and lifecycle tested to ensure long service life.

### Burner Technology

Powrmatic working alongside market leading burner manufacturer Riello now utilise a pre-fitted and tested low NOx, high-low control "Gulliver" burner as standard.

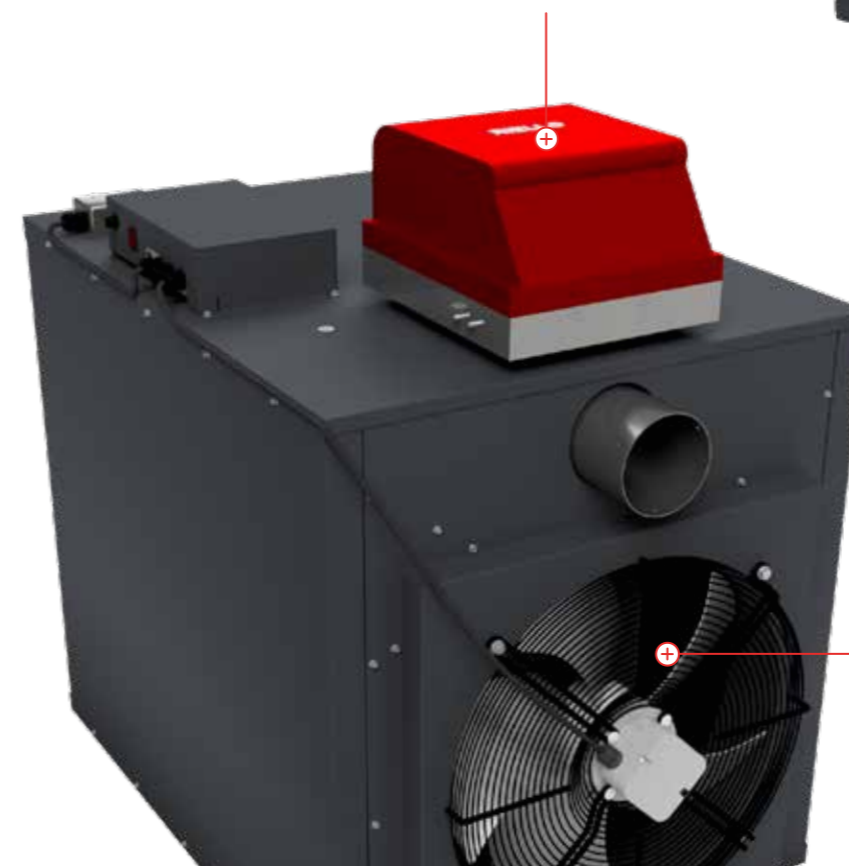

## Approvals CE

OUH heaters are type tested and CE approved. In addition CPx heaters heaters made available to the market from September 2018 onwards comply with the requirements of the Directive 2009/125/EC - Lot 21 Tier 1.

### Air Movement

Axial fan heaters are fitted with a single fan set and discharge warmed air directly into the heated space via adjustable horizontal louvers. Vertical louvres are available as an option where lateral air discharge is required. Centrifugal fan models benefit from a close coupled fan which discharges warmed air via a duct outlet spigot suitable for the onward connection of ductwork.

Model		20	30	45	60		
Output (nominal)	High Fire (Max)	kW	20	30	45	60	
	Low Fire (Min)	kW	16	24	34	45	
Airflow	Volume	OUH F	m³/s	0.7	0.82	1.19	1.94
		OUH C	m³/s	1.0	0.82	1.19	1.88
	Throw	OUH F	m	8.5	16	25	34
	Fan Static	OUH C	Pa	275	305	275	384
Electrics	Supply	Standard	V/ph/Hz	230/1/50			
		Optional	V/ph/Hz	415/3/50			
	Run Current	OUH F	amp	0.94	0.46	0.48	1.7
OUH C		amp	4.3	4.33	5.54	8.0	
Fuel Oil	Connection	BSP/Rc	¾				
	Consumption	l/h	2.18	3.18	5.32	6.70	
Mounting Height	OUH F	Min	m	2.50	3.00		
		Max	m	3.00		5.00	
Overall Dimensions	Height	mm	806	1043	1049	1049	
	Width	mm	555	780	780	780	
	Depth	OUH F	mm	868	1106	1115	1150
OUH C		mm	1163	1470	1469	1469	
Installation Clearances	Top	mm	1000				
	Side	mm	500				
	Rear	mm	400				
Flue diameter	mm ø	100	125				
Combustion Air Spigot	mm ø	150					
Maximum Combustion Duct Length *	m	120	100	81	21		
Noise Level - OUH F models	dB(A)	46	54	52	53		
Nett Weight	OUH F	kg	53	126	126	126	
	OUH C	kg	91.5	142	142	142	
Model		20	30	45	60		

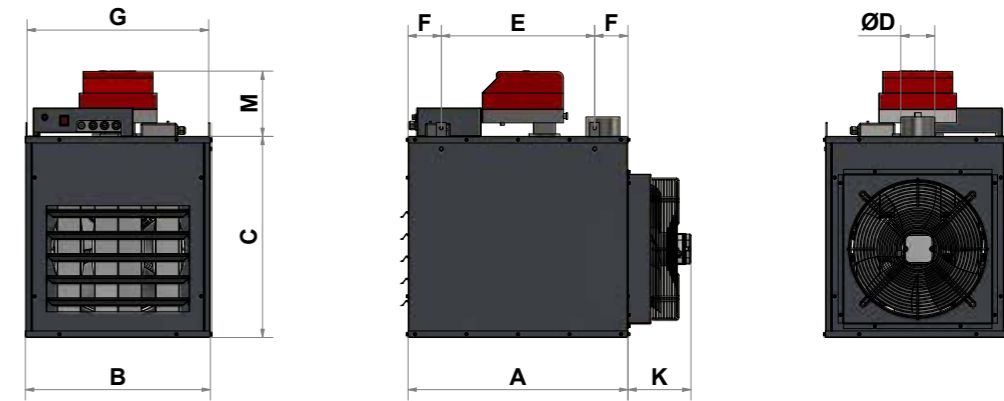

Model	A	B	C	D	E	F	G	K	M
OUH F 20	668	555	610	100	465	101	549	200	196

## OUH F 30/45/60 - Axial Freeblowing Fan Unit

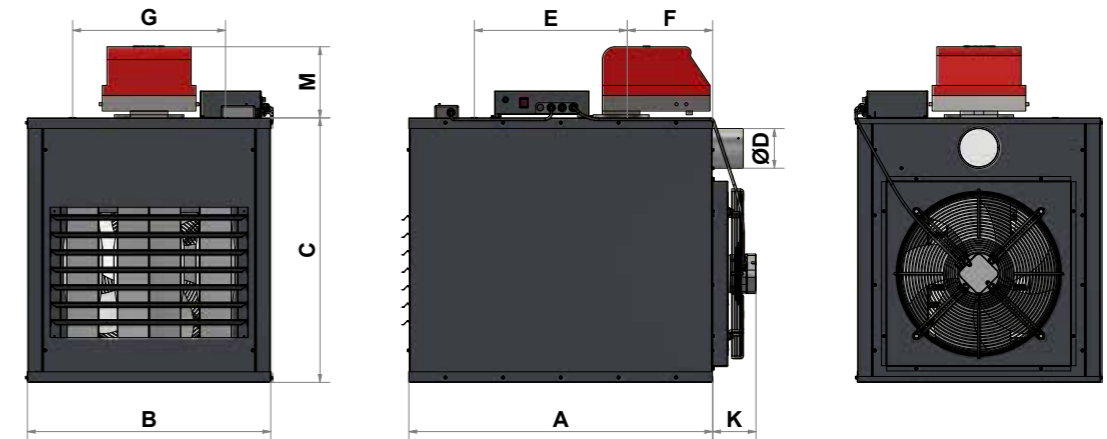

Model	A	B	C	D	E	F	G	K	M
OUH F 30	975	780	847	125	490	276	490	131	196
OUH F 45	975	780	847	125	490	276	490	140	202
OUH F 60	975	780	847	125	490	276	490	175	202

- Notes:**
- Fuel consumption and output figures based upon nett calorific value as follows:
    - Class D light distillate fuel oil Nett CV 36.28 MJ/l
  - OUH heaters have efficiency levels which comply with the requirements of United Kingdom Part L Building Regulations and the seasonal efficiency requirements of the Ecodesign regulation (EU) 2015/1188, Directive 2009/125/EC – Lot 21 Tier 1B (Known as ErP and mandatory as from September 2018)
  - Air handling data is assessed at room ambient conditions
  - Throw figures provide the distance to the point where the terminal velocity degrades to 0.25 m/s
  - Noise levels refer to OUH F axial fan models and measured 5m from appliance and in free field conditions
  - Where NVxD heaters are to be applied installers should be aware of both the minimum and maximum airflows as well as a need for fan over-run facilities to protect the heater. It is recommended that you consult with Powrmatic Technical Support prior to product selection and installation
  - Motor, run and start amps apply to standard electrical supply as stated. For optional data contact sales
  - Combustion air spigot is an optional extra
  - For extended combustion duct lengths please contact Powrmatic Technical Support
  - For Installer guidance notes see page 7

# Dimensions

## OUH C 20 - Centrifugal Fan Unit

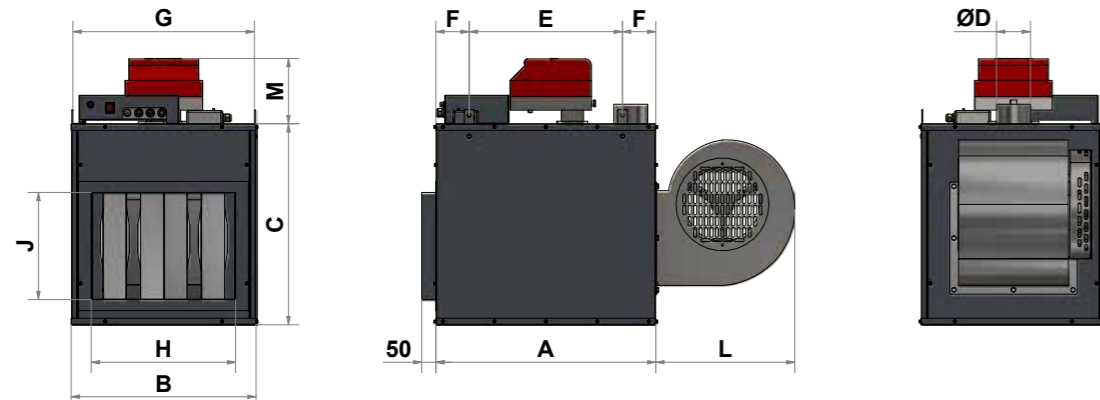

Model	A	B	C	D	E	F	G	H	J	L	M
OUH C 20	668	555	610	100	465	101.5	549	410	340	495	196

## OUH C 30/45/60- Centrifugal Fan Unit

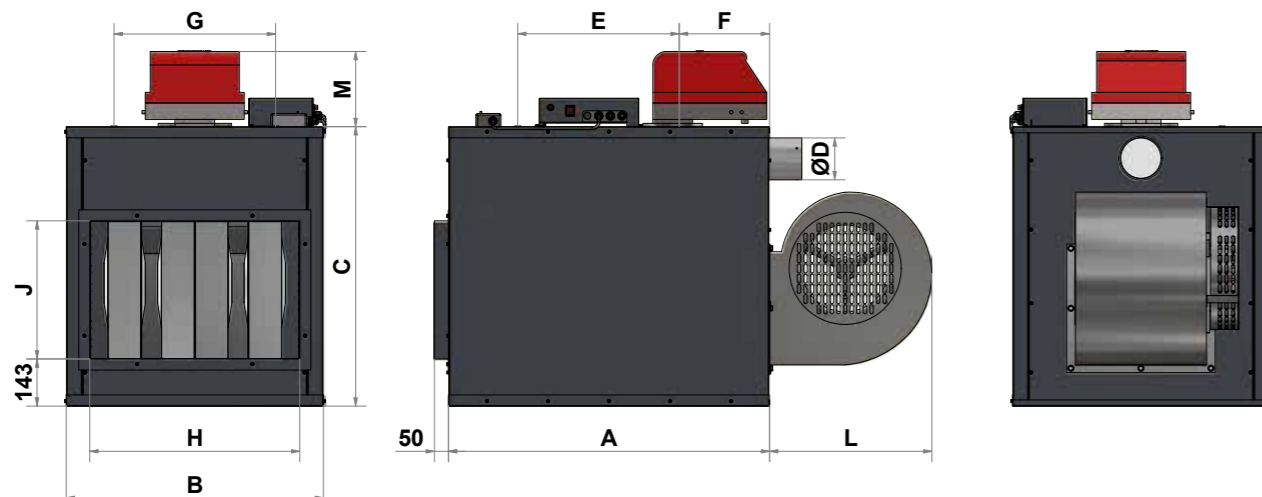

Model	A	B	C	D	E	F	G	H	J	L	M
OUH C 30	975	780	847	125	490	276	490	636	418	495	196
OUH C 45	975	780	847	125	490	276	490	636	418	494	202
OUH C 60	975	780	847	125	490	276	490	636	418	494	202

# Your Installer Guide

### General

The following notes are provided as a guide, however installers and users should fully acquaint themselves with the more detailed guidance provided in the relevant Installation, Operation and Maintenance Manual. For copies of such manuals please consult our technical department or visit our website - [www.powrmatic.co.uk](http://www.powrmatic.co.uk)

### Standards

OUH heaters must be installed, commissioned and operated with due regard to appropriate regulations including but not limited to relevant Codes of Practice, the possible requirements of Local Authorities, Fire Officers and insurers as the relevant Installation, Operation and Maintenance Manual.

### Position & Location

Powrmatic OUH heaters can be 'drop rod' suspended via purpose designed M10 suspension fixing points, attached to our optional wall support brackets or positioned on a level non-combustible base. In all cases it is important that all supporting structures have due regard to the relevant weight loadings.

Consideration should also be given to flue routes and points of exit, oil, electrical and control connections, the throw characteristics of the heater, issues of public access and the siting of environmental control stations and/or remote temperature sensors where the position needs to be representative of the zone temperature to which they refer.

Heaters should not be installed in hazardous areas or areas where there is a foreseeable risk of flammable or corrosion inducing particles, gases or vapours being drawn into the combustion air or main fan circuits

Areas where special consideration or advice may be required could include but is not limited to -

- Where de-greasing solvents are present, even in minute concentrations
- Where paint spraying is carried out
- Where styrenes or other laminating products are used
- Where airborne silicone is present
- Where petrol engined vehicles are stored or maintained
- Where dust is present (ie wood working or joinery shops)
- Where high levels of extract persist

Installation in such areas may be possible under specific conditions. Please consult our technical department or your local sales manager for further information.

### Plant Room or Enclosure Locations

It is possible to install centrifugal fan variants of the OUH heater within plant rooms or enclosures however specific requirements may need to be applied. Such requirements cover the provision of positive ductwork connections as well as ventilation for combustion air and general plant room or enclosure ventilation. It is recommended that you consult with our technical department or the Installation, Operation and Maintenance Manual.

### Combustion Air & General Ventilation

Our recommendation is that where a heater is installed directly within the heated space and where that heated space has a natural ventilation rate greater than 0.5 air changes per hour then combustion air and general heater ventilation is probably not required.

If the heated space has a natural ventilation rate of less than 0.5 air changes per hour then either natural ventilator openings or mechanical ventilation may be required. Please consult the relevant Installation, Operation and Maintenance Manual for further details.

### Installation Clearances

Particular clearances may be necessary for the correct and safe function of the heater as well as for maintenance purposes. Such clearances are confirmed in the relevant Installation, Operation and Maintenance Manual.

### Flue

For internally located heaters each heater requires a separate flue system of the appropriate size. The flue should essentially be installed in the vertical plane and the number of bends kept to a minimum.

The flue must be adequately supported and terminated with a suitable cowl, with due regard to the point of exit and it's proximity to any windows, doors or ventilation intakes.

External heaters are supplied complete with a primary flue section and cowl which provides the direct discharge of flue gases directly to atmosphere. Care should be taken to ensure that the flue discharge is not in anyway restricted or the exit point such that flue gases can enter a building.

If the application requires it may be possible to extend the flue of external heaters to enable the point of discharge to be repositioned. However should this be necessary then the diameter of flue must not be less than stated in the data sections of this brochure.

### Ductwork

OUH heaters can be fitted with distribution ductwork and/or inlet or return air duct connections. In such circumstances the OUH C centrifugal fan model should be selected and installers must ensure that the combined duct resistances, including grilles, filters, dampers or other ductwork components are balanced to closely match the static pressure as shown on page 4 of this brochure. Insufficient or excessive duct resistance will compromise the performance of the heater. Please consult our technical department or your local area sales manager for further guidance.

### Pipework

Care should be taken when sizing pipework to ensure that maximum oil inlet pressures and flow rates are not compromised under dynamic load conditions. Isolating valves and service unions should be provided for each heater and pipework installed with due regard for relevant standards and Codes of Practice.

### Guarantee

Powrmatic heaters are provided with a comprehensive guarantee covering both the heater and the heat exchanger. For United Kingdom and Ireland sales the heater has the benefit of a two year parts and one year labour guarantee. The combustion chamber/heat exchanger has a ten year time related sliding scale warranty. All guarantees are subject to terms and conditions.



# About Us

Powrmatic design, develop and deliver HVAC solutions worldwide across a wide range of commercial and industrial applications creating comfortable and safe environments, differentiated through innovation, integrity, compliance and service.

Our specialised HVAC divisions:

## Heating

Industrial and commercial warm air and radiant space heating solutions manufactured to achieve efficient performance, compliance and reliability for every application in partnership with the HVAC trade.

## Ventilation

Custom designed highly efficient, cost-effective smoke, natural and powered ventilators manufactured to meet project requirements of building operators, architects, specifiers and contractors.

## Air Conditioning

Worldwide distributors of innovative wall mounted packaged heat pumps and traditional split and multi split air conditioners for every sector providing efficient comfort cooling and heating all year round.

## Engineered Products

Bespoke heating and ventilation solutions designed to serve individual customers specific project requirements. In addition our OEM products provide partner AHU manufacturers with high quality energy efficient gas fired heat exchangers.

## Contact Us

Powrmatic Limited  
Hort Bridge, Ilminster  
Somerset  
TA19 9PS  
tel: **+44 (0) 1460 53535**  
fax: **+44 (0) 1460 52341**  
e-mail: **info@powrmatic.co.uk**



#keepingthenationwarm

Powrmatic Ireland  
45 Broomhill Close  
Tallaght  
Dublin 24  
tel: **+353 (0) 1452 1533**  
fax: **+353 (0) 1452 1764**  
e-mail: **info@powrmatic.ie**



Powrmatic pursues a policy of continuous improvement in both design and performance of its products and therefore reserves the right to change, amend or vary specifications without notice. Whilst the details contained herein are believed to be correct they do not form the basis of any contract and interested parties should contact the Company to confirm whether any material alterations have been made since publication of this brochure.