



POWRMATIC®

Delivering complete climate control solutions worldwide

Same style.
Same quality.
Increased efficiency.

The new VX from Powrmatic.

VX Range

Power Vented Gas
Cabinet Heater
Natural Gas & LPG Fired Options



ErP Ready

New For 2021

www.powrmatic.co.uk

VX Power Vented Gas Cabinet



VX Installer Benefits



REDUCED NO_x
ErP READY 2021



SAME DESIGN
& **QUALITY**



EASY ENGINEERS
ACCESS

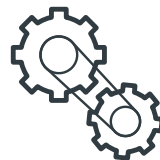

SIMPLIFIED
START UP



INSTANT ONLINE
COMMISSIONING

Compact Efficient Compliant

The all new VX From Powrmatic

The ErP 2021 compliant floor standing VX range of cabinet heaters from Powrmatic benefits from the same design as the popular VX range in its entire construction, performance, and aesthetics, finished with the popular epoxy powder RAL 7015 stove baked paint.

With six models in the range between 35kW and 140kW. VX heaters can be configured for either room sealed or flue only operation. Vertical and horizontal fluing options add benefit and savings for installers.

The VX is designed to offer ErP compliant NO_x emissions and seasonal efficiencies providing cost effective solutions for a wide variety of industrial and commercial buildings.

Models Available

- VX UF - Upright Free Blowing Unit
- VX UD - Upright Ducted Unit



Product Features

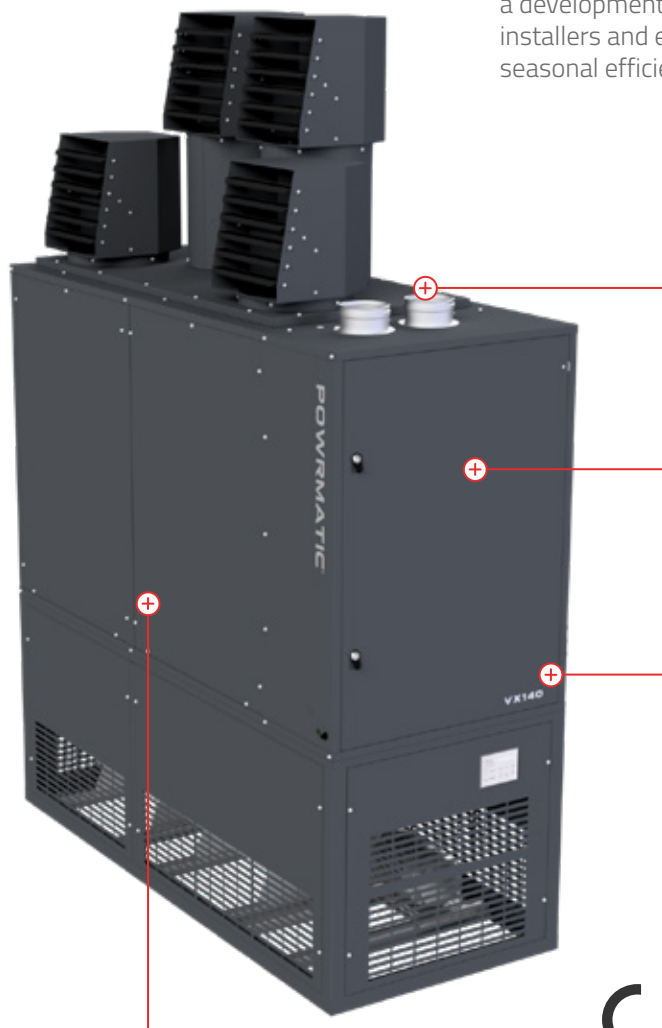

Reduced NOx Emissions

Powrmatic's VX range of gas fired floor standing cabinet type heaters are a development of the highly successful VPx range familiar to specifiers, installers and end users alike. The new range meets the NOx emission and seasonal efficiency levels demanded by the latest ErP regulations

Horizontal Discharge Option

Depending on application and heater location, the VX can be specified with horizontal low level flue discharge, this can help to minimise costly roof penetrations. A vertical flue option can also be specified.

Easy Access Control Panel

The VX has been designed with engineers in mind. The hinged electrical panel provides easy access to the burner compartment for routine servicing and maintenance whilst on-site wiring connections have been optimised to speed up installation.

Factory Fitted and Pre-Wired Controls

All VX heaters are provided with Powrmatic's MC200 integrated digital control. The optimised start, programmable time and temperature setting options and password protection functionality of the control combine to offer efficient utilisation of the fuel.

Approvals

VX heaters are type tested and CE approved. In addition, VX heaters made available to the market 2021 onwards comply with the requirements of the Directive 2009/125/EC - Lot 21 Tier 2 (ErP) regulations.



Compact Construction

VX dimensions have been reduced providing greater flexibility in choice of applications and locations. The construction is of the familiar frame and panel construction with the lower panels designed to accept a choice of inlet options including fresh and return air spigots, dampers and filters.

Extended Range & Heat Exchanger Options

The new VX range features six models with a maximum output of 140 kW. In addition, the robust and proven four pass tubular heat exchanger is manufactured as standard from aluminised steel formed, swaged and expanded without the use of stress inducing welding. For harsher environments 409 and 316 grade stainless steel options are available.



Technical Specification

VX

Model			35	50	70	90	120	140	
Output (nominal)	High Fire (max)	kW	33.5	49.1	69.8	88.4	119.2	138.3	
	Low Fire (min)	kW	16.1	23.8	34.0	41.2	67.7	72.7	
Input (nett CV)	High Fire (max)	kW	35.8	53.6	75.3	94.9	127.0	147.5	
	Low Fire (min)	kW	16.8	25.1	35.1	43.6	70.1	75.0	
NOx Seasonal (Gross)		mg/kWh	66.8	48.3	53.9	38.7	66.8	61.2	
Seasonal Space Heating Energy Efficiency		% hs,h	80.5	79.2	80.5	79.8	79.6	80.0	
Air Flow Volume		m³/s	1.11	1.51	1.94	2.81	3.56	3.75	
Airflow	Heads		3			4			
	Throw		m	12	22	25	27	30	32
	Fan Static	Standard	Pa	250	250	250	180	290	250
		Up rated	Pa	400	400	400	400	400	400
Electrics	Supply	Standard	V/ph/Hz	230/1/50					
		Optional*	V/ph/Hz	N/A		<i>(400/3/50)</i>			
	Start Current		amp	4.7	7.6	11 <i>(5.3)</i>	12.8	17 <i>(4.6)</i>	20 <i>(4.9)</i>
	Run Current		amp	15.6	26.3	38 <i>(18)</i>	31.0	40 <i>(14.9)</i>	44 <i>(16.8)</i>
Fuel	Connection		BSP/Rc	¾"			1"		
	Nominal Inlet Pressure	Nat Gas	mbar	20.0					
		LPG	mbar	37.0					
	Consumption	Nat Gas	m³/h	3.79	5.67	7.96	10.04	13.44	15.61
LPG		m³/h	1.46	2.19	3.08	3.88	5.19	6.03	
Overall Dims	VX UF	Height	mm	2184	2286	2381	2607	2607	2722
		Width	mm	819	819	819	819	819	819
		Depth	mm	1325	1325	1325	1950	1950	1950
Install Clearance	VX UF	Front	mm	1000					
		Blank Side	mm	150 (wall facing side)					
		Louvred Side	mm	500					
		Rear	mm	500					
		Above	mm	1000					
Flue	Diameter		mm Ø	100	100	130	130	130	130
	Maximum Length	Flue Only	m	12					
		Room Sealed	m	6					
Combustion Air Spigot		mm Ø	100			130			
Noise Levels	VX UF	dB(A)	60	62	63	68	69	70	
Nett Weight	VX UF	kg	180	209	287	426	468	542	
Model			35	50	70	90	120	140	

Notes:

Fuel Consumption and input figures based upon nett calorific values as follows: -
Natural Gas (G20) nett CV 34.02 MJ/m³ - Propane (G31) nett CV 88.00 MJ/m³

- Heaters have efficiency levels which meet with the minimum heater efficiency requirements of UK Part L Building Regulations.
- VX heaters comply with the seasonal efficiency and NOx limits requirements of the Ecodesign regulation (EU) 2015/1188, Directive 2009/125/EC – Lot 21 Tier 2 (ErP)
- Air handling data is assessed at room ambient conditions
- Throw figures provide the distance to the point where the terminal velocity degrades to 0.25m/s
- Dimensions in the table above refer to VX UF units only - for data on all other models refer to the dimensions page and/or the installation instructions.

- Noise levels are applicable to standard VX UF models and are measured 5m from appliance in a free field.
- Motor kW, run and start amps apply to standard electrical supply as stated. For optional data contact sales office.
- Optional 3 phase direct drive centrifugal blowers shown in italics within brackets()*
- Connection of combustion air duct is not required for 'flue only' applications.
- It is the responsibility of the installing contractor to ensure that ductwork is correctly sized and balanced when installing VX UD units.

Dimensions

VX 35-140 UF /UD

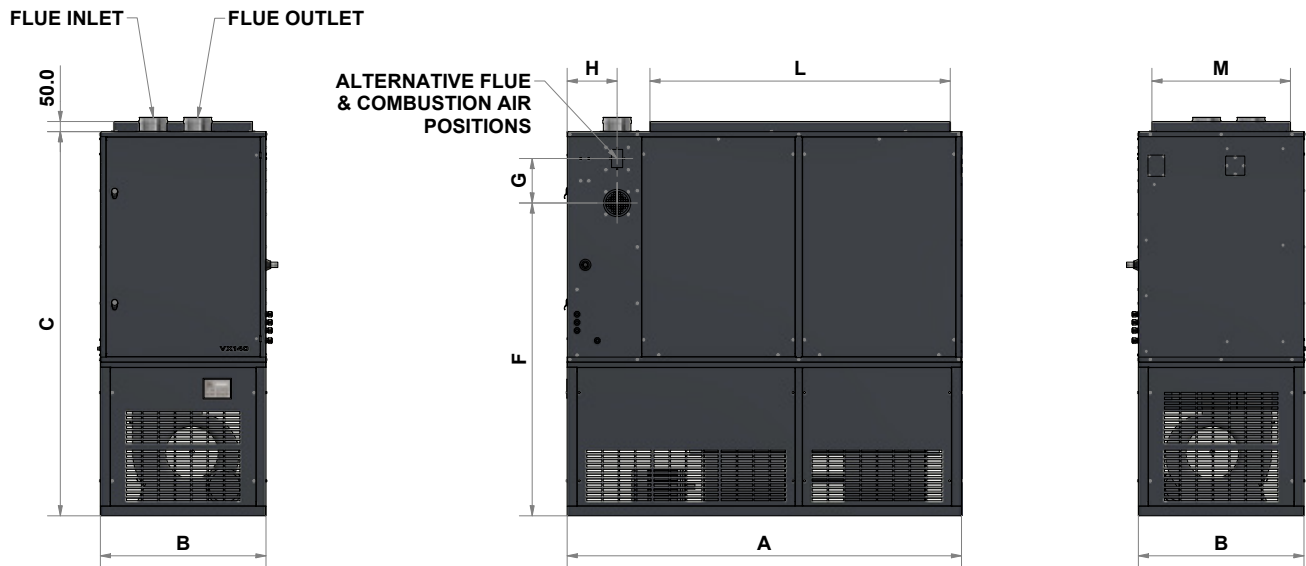
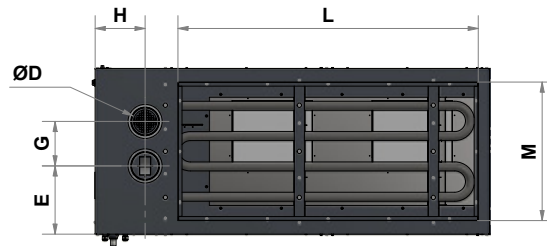

Model		35	50	70	90	120	140
A	mm	1325	1325	1325	1950	1950	1950
B	mm	819	819	819	819	819	819
C	mm	1672	1672	1672	1900	1900	1900
DØ	mm	100	100	130	130	130	130
E	mm	356	356	356	337	337	337
F	mm	1314	1314	1236	1547	1547	1547
G	mm	142	142	220	220	220	220
H	mm	237	237	237	247	247	247
J	mm	255	286	345	345	345	400
J1	mm	512	614	709	707	707	822
K	mm	207	256	308	308	308	320
L	mm	915	915	915	1485	1485	1485
M	mm	685	685	685	685	685	685

Accessories Dimensions

VX

Side/Rear Inlet Spigot

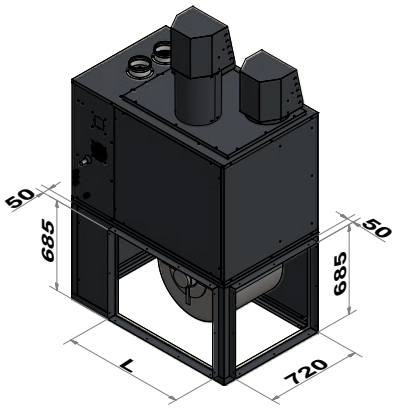

Side/Rear Filters

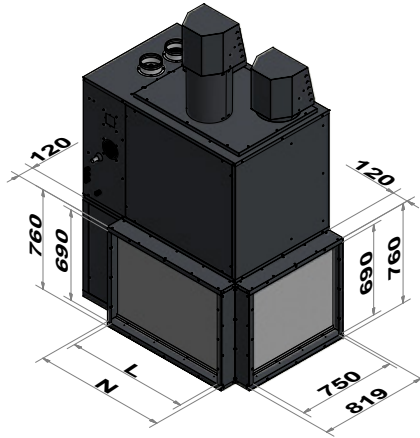

Side/Rear Dampers

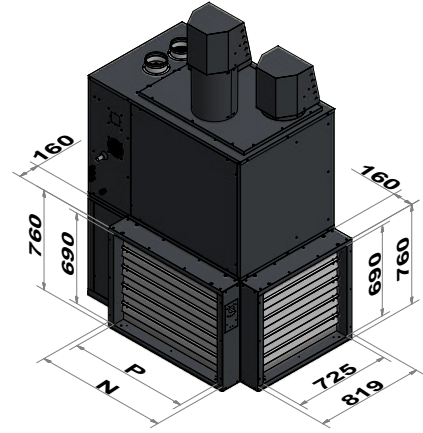

Model	30	50	70	90	120	140
L		915			1485	
N		995			1620	
P		900			1525	

Notes:

- All spigot dimensions are outside dimensions
- EU1 Standard filter specification is 10ppi (parts per inch)
- Higher specification filters available on request - contact our Technical Support Department for more information
- Standard dampers are manual operation - motorised options available
- Installer guidance notes on page 7

Head Plan Options

VX

Head Plan 1

(35, 50 & 70)

Head Plan 2

(90, 120 & 140 only)

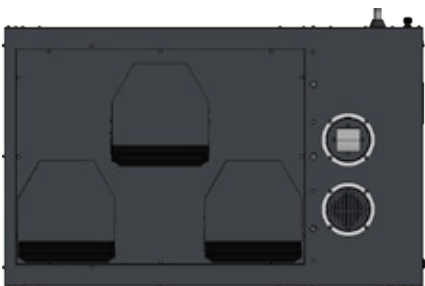

Flue Arrangements

VX Room Sealed & Flue Only Flue Systems

Room Sealed - Horizontal Flue System

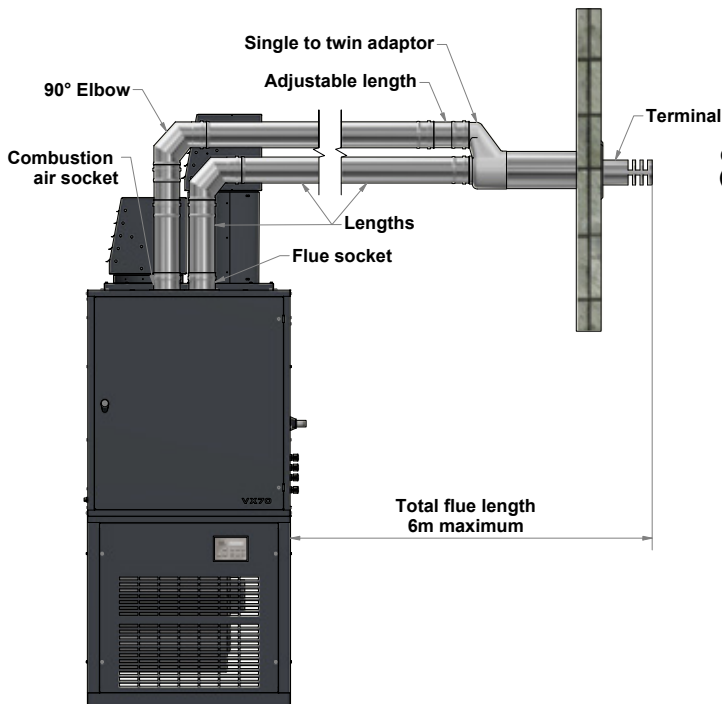

Flue Only- Horizontal Flue System

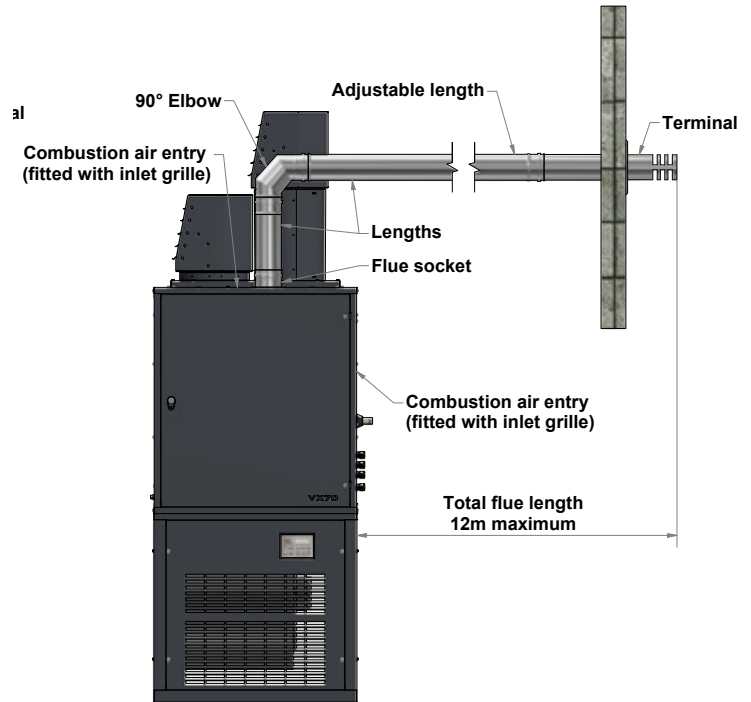

Room Sealed - Vertical Flue System

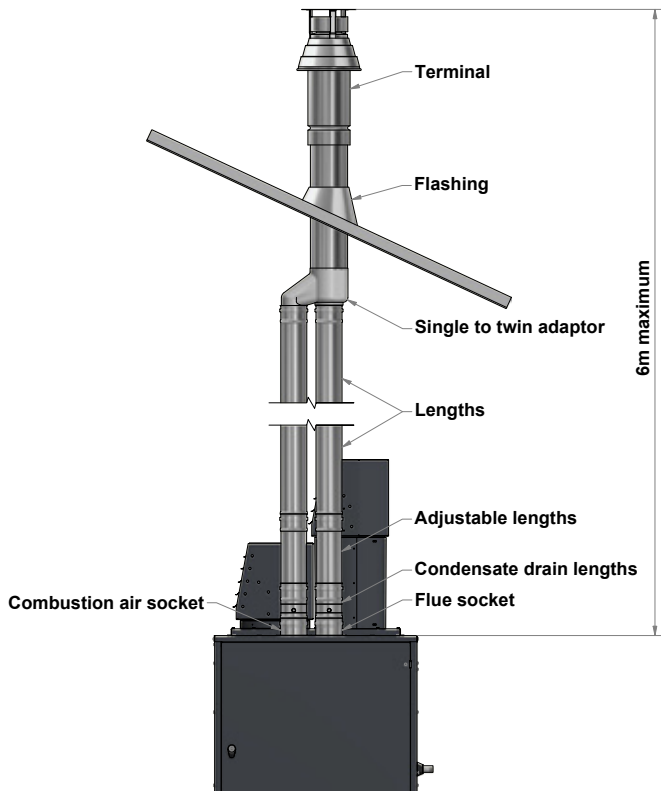

Flue Only- Vertical Flue System

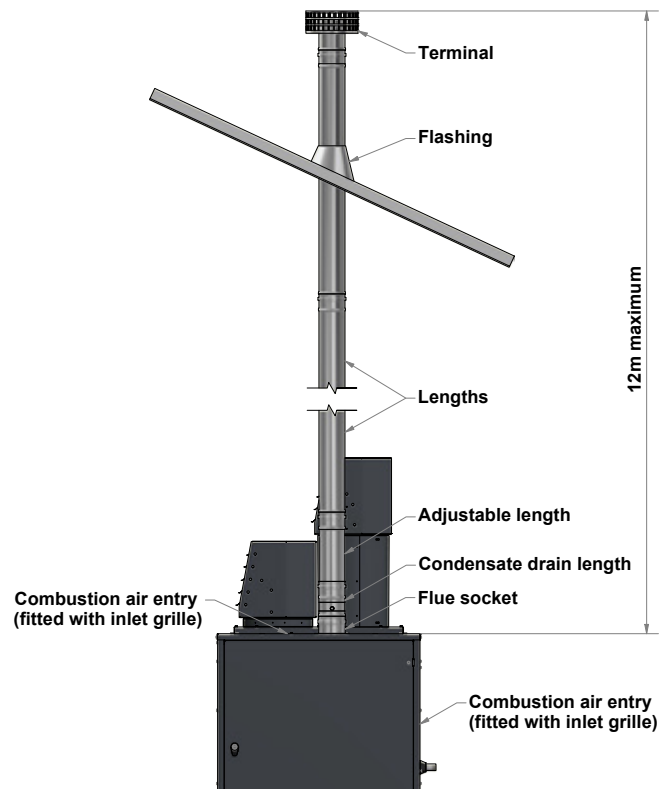

Notes for all systems:

- Maximum flue/combustion air length is 6m and on flue only installations maximum flue length is 12m.
- Final overall length of adjustable disconnection piece must be between 360-415mm.
- 45° offsets may be used if required. Each set is equivalent to 0.5m of flue length.
- 90° offsets may be used if required. Each set is equivalent to 1m of flue length.
- Where VX heaters are used in clean environments it is permissible to take the combustion air directly from the heated space. The supplied mesh intake plate must be fitted to the combustion air inlet on the rear of the heater.
- If fitted with vertical flue, Powrmatic recommend the installation of a condensate drain length.

Flue Components

Vertical & Horizontal Flue Kits

Concentric Vertical Terminal Kit

Unit	Part Number	A mm	B mm	C mm	D mm	E mm
VX 35 & 50	NVC/VTK2	100	550	145	770	150
VX 70- 140	NVC/VTK3	130	960	250	560	200

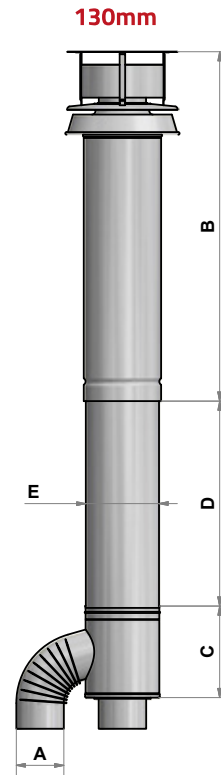
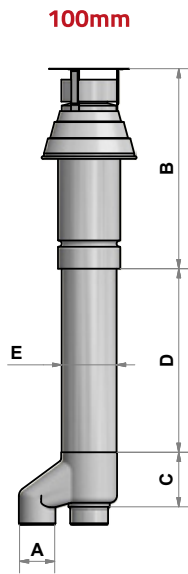

Concentric Horizontal Terminal Kit

Unit	Part Number	A mm	B mm	C mm	D mm	E mm
VX 35 & 50	NVC/HTK2	100	170	145	560	150
VX 70- 140	NVC/HTK3	130	185	250	420	200

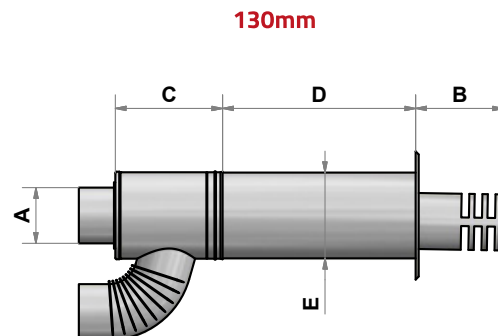
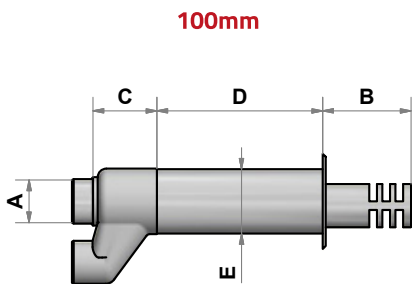

General

The following notes are provided as a guide, however installers and users should fully acquaint themselves with the more detailed guidance provided in the relevant Installation, Operation and Maintenance Manual. For copies of such manuals please consult our technical department or visit our website - www.powrmatic.co.uk

Standards

VX heaters must be installed, commissioned and operated with due regard to appropriate regulations including but not limited to BS 6230, relevant Codes of Practice, the possible requirements of Local Authorities, Fire Officers and insurers as well as the Installation, Operation and Maintenance Manual.

Position & Location

Heaters should be installed on a level non-combustible base. Consideration should also be given to flue routes and points of exit, gas, electrical and where applicable control connections, the throw characteristics of the heater, issues of public access and in the instance of remote temperature sensors the position needs to be representative of the zone temperature to which they refer.

Heaters should not be installed in hazardous areas or areas where there is a foreseeable risk of flammable or corrosion inducing particles, gases or vapours being drawn into the combustion air or main fan circuits.

Areas where special consideration or advice may be required could include but is not limited to -

- Where de-greasing solvents are present, even in minute concentrations
- Where paint spraying is carried out
- Where styrenes or other laminating products are used
- Where airborne silicone is present
- Where petrol engined vehicles are stored or maintained
- Where dust is present (i.e. wood working or joinery shops)
- Where high levels of extract persist

Installation in such areas may be possible under specific conditions. Please consult our technical department or your local area sales manager.

Plant Room or Enclosure Locations

Specific requirements exist where heaters are to be installed in a plant room or enclosure. Such requirements include the provision of positive ductwork connections as well as ventilation for combustion air and general ventilation. It is recommended that you consult with our technical department or your local area sales manager for further guidance.

Installation Clearances

Particular clearances may be necessary for the correct and safe function of the heater as well as for maintenance purposes. Such clearances are confirmed in the relevant Installation, Operation and Maintenance Manual.

Combustion Air & General Ventilation

Within the United Kingdom mandatory regulations apply concerning the provision of combustion air and general heater ventilation. Where a heater is installed in room sealed mode (ie where both the flue exit and combustion air are positively connected to atmosphere) then there is no specific requirement for combustion air ventilation. However, depending upon location, provision for general ventilation may still be a necessity.

If the heater is installed in flue only mode and directly within the heated space and where that heated space has a natural ventilation rate greater than 0.5 air changes per hour then combustion air and general heater ventilation is probably not required. If the heated space has a natural ventilation rate of less than 0.5 air changes per hour then either natural ventilator openings or mechanical ventilation will be required. Please consult the Installation, Operation and Maintenance Manual for further details.

Flue

VX heaters can be installed in either room sealed or flue only mode. Each heater requires a separate flue and/or combustion air intake system of the appropriate size and type. Installers are reminded that type approval has been granted for these appliances on the basis that they are fitted with Powrmatic VX flue systems. Maximum lengths apply and should be strictly observed.

Systems may be installed in either the horizontal or vertical plane. In either case the number of bends kept to a minimum and regard must be given to the reduction in permissible length with the addition of each bend. The flue must be adequately supported and terminated with the approved terminal assembly, with due regard to the point of exit and its proximity to any windows, doors or ventilation intakes.

Ductwork

VX heaters can be fitted with distribution ductwork and/or inlet or return air duct connections. Installers must ensure that the combined duct resistances, including grilles, filters, dampers or other ductwork components are balanced to closely match the static pressure as shown on page 4 of this brochure.

Insufficient or excessive duct resistance will compromise the performance of the heater. Please consult our technical support department or your local area sales manager for further guidance.

Pipework

Care should be taken when sizing pipework to ensure that minimum gas inlet pressures are not compromised under dynamic load conditions. Isolating valves and service unions should be provided for each heater and pipework installed with due regard for relevant standards and Codes of Practice.

Guarantee

Powrmatic VX heaters are provided with a comprehensive guarantee covering both the heater and the heat exchanger. For United Kingdom sales the heater has the benefit of a two year parts and one year labour guarantee whilst the heat exchanger assembly has a ten year time related warranty. All guarantees are subject to terms and conditions.



**TIME RELATED
HEAT EXCHANGER
WARRANTY**

About Us

Powrmatic design, develop and deliver HVAC solutions worldwide across a wide range of commercial and industrial applications creating comfortable and safe environments, differentiated through innovation, integrity, compliance and service.

Our specialised HVAC divisions:

Heating

Industrial and commercial warm air and radiant space heating solutions manufactured to achieve efficient performance, compliance and reliability for every application in partnership with the HVAC trade.

Ventilation

Custom designed highly efficient, cost-effective smoke, natural and powered ventilators manufactured to meet project requirements of building operators, architects, specifiers and contractors.

Air Conditioning

Worldwide distributors of innovative wall mounted heat pumps air conditioner technology providing efficient comfort cooling and heating all year round.

Engineered Products

Bespoke heating and ventilation solutions designed to serve individual customers specific project requirements. In addition our OEM products provide partner AHU manufacturers with high quality energy efficient gas fired heat exchangers.

Contact Us

Powrmatic Limited
Hort Bridge, Ilminster
Somerset
TA19 9PS
tel: **+44 (0) 1460 53535**
fax: **+44 (0) 1460 52341**
e-mail: **info@powrmatic.co.uk**



#keepingthenationwarm

Powrmatic Ireland
45 Broomhill Close
Tallaght
Dublin 24
tel: **+353 (0) 1452 1533**
fax: **+353 (0) 1452 1764**
e-mail: **info@powrmatic.ie**



Powrmatic pursues a policy of continuous improvement in both design and performance of its products and therefore reserves the right to change, amend or vary specifications without notice. Whilst the details contained herein are believed to be correct they do not form the basis of any contract and interested parties should contact the Company to confirm whether any material alterations have been made since publication of this brochure.