

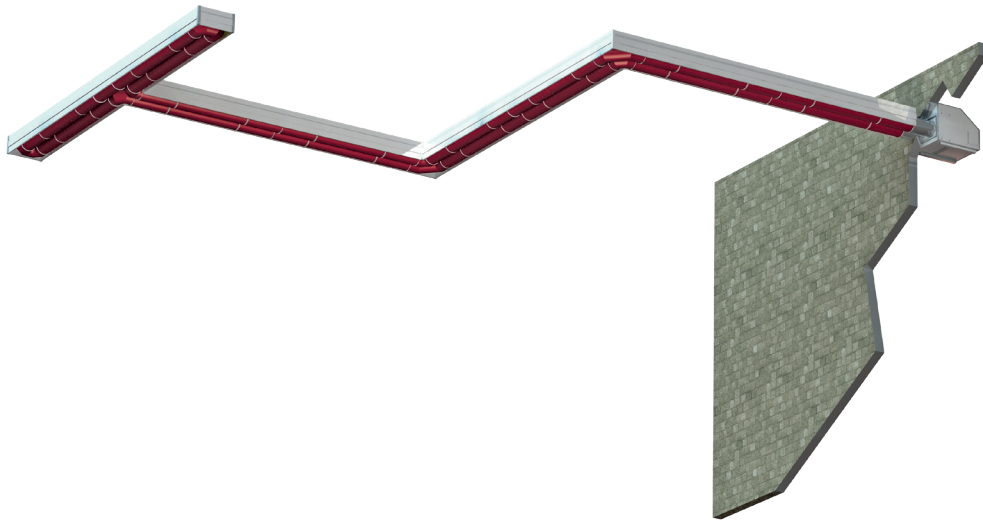

# Girad

Single Burner Continuous Radiant Strip Heating System



*Innovation  
in design*

*Bespoke  
solutions  
made easy*

Find Your perfect Heating Solution

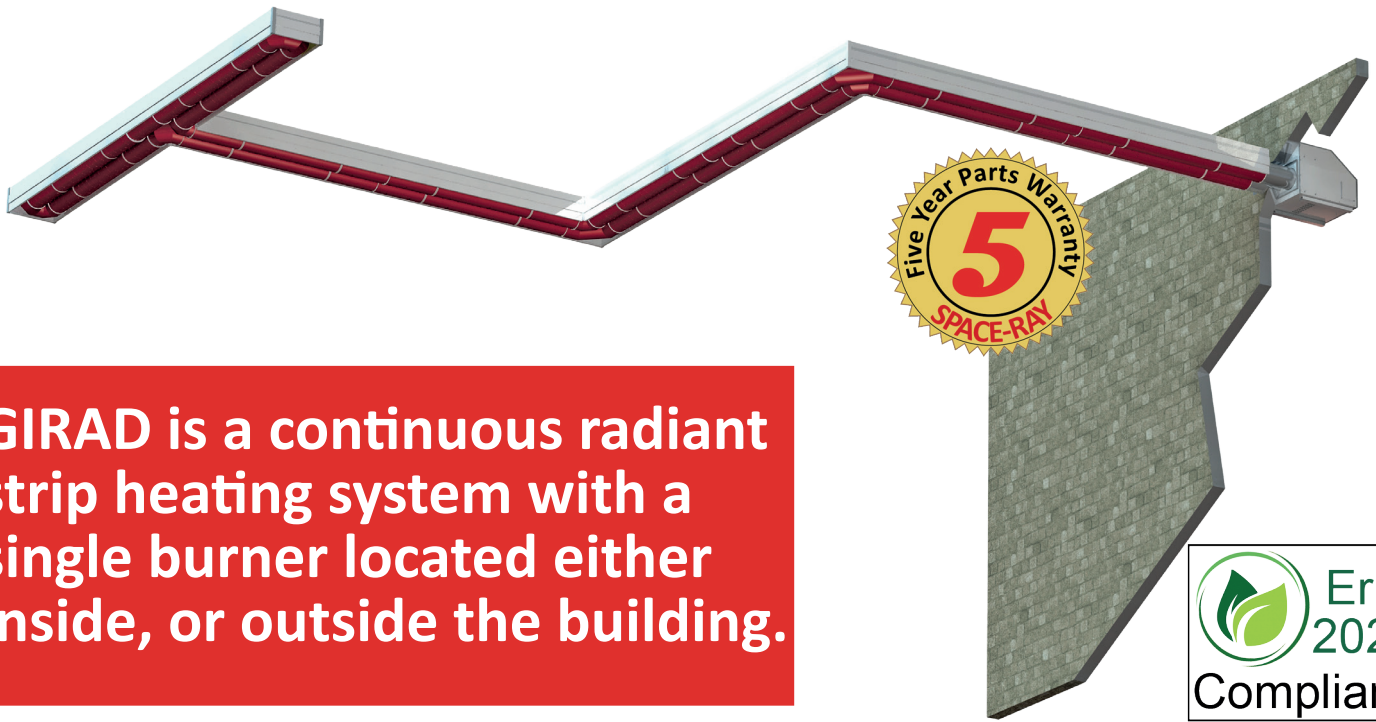

**GIRAD is a continuous radiant strip heating system with a single burner located either inside, or outside the building.**

Available with a total of seven input ratings from 50kW up to 300kW for wall or roof mounting, internally or externally.

Tube diameters of 200mm and 300mm and a maximum tube length of up to 324m.

For use with natural gas or LPG. A limited number of models can be used on oil.

Heating modules incorporate ECOMIX air & gas modulating burners which are connected

Girad is a single burner continuous radiant heating system, suitable for heating a wide range of applications including warehouses, workshops, factories, aircraft hangars & distribution centres. One of the many benefits of the Girad system is that the burner module can be mounted on the outside of the building, or if inside, external to the space being heated.

When the heating module is mounted externally, it also offers the client the added benefit of no gas supplies being run inside the building.



Configuration of a twin tube assembly showing double skin reflector with internal insulation

to the radiant tubes at high level and operate on a 'closed circuit' basis, where the products of combustion are used as the heating medium by being re-circulated through the tubes.

The burner will maintain the correct temperature of the gases within the tubes in order to satisfy the temperature requirements of the space sensor or thermostat.

Heat is distributed throughout the space via the high level radiant tube system, therefore no moving or serviceable parts exist within the space meaning no disruption to the client, whilst the heating module is being serviced.

The Girad system achieves high efficiencies of up to 95.5% (ncv) and reduced NO<sub>x</sub> emissions by re-circulating a percentage of the combustion (flue) gases around the sealed circuit of the radiant tubes.

The air & gas modulating burner ensures that the optimum space temperature is effectively & efficiently achieved, by raising the temperature of the gases within the radiant tubes and in turn their surface temperature.

On start up the burner will operate on full fire to reach set-point temperature, once achieved the burner will modulate down to low fire (or any point in between) to maintain the set-point temperature.

### System Benefits

- Burner can be located outside of the space being heated.
- Single point of service. No parts within the space require servicing.
- Efficient modulating burner
- Significant installation savings compared to multi burner systems.
- Fan & burner mounted outside of space, therefore no component noise.
- Flexible layout with up to 324m tube run (model dependent).
- A number of control options available - standalone (Crono 30), remote control (with additional software) or BMS gateway.

## ECOMIX Burner

The patented ECOMIX burner is at the heart of each Girad heating module and consists of a number of venturi Air Vein burners working within a positive pressure, high speed (7 to 15m/s) air stream.

This provides the ECOMIX burner with unique features when compared to traditional blown burners:-

- Highly reliable: No moving parts
- High turndown ratio: Up to 10:1
- Low burner emissions
- Air damper maintains constant 'best' combustion efficiency from minimum to maximum output (stoichiometric combustion)



*Need to ask a question?  
Call us: +44 (0) 1473 830 551*

### Joining Tubes & Reflectors Together

Flanged 'cone shaped' joints and securing rings are used to join the radiant tubes, these ensure excellent tightness levels at installation and over time. This helps avoid air infiltration into the radiant tubes, which will result in a reduced thermal efficiency of the heating system .

Connecting the reflector assemblies together utilises a bayonet and slot fixing, this provides a quick and easy method of joining and uses no loose fixings or tools.



Before



After

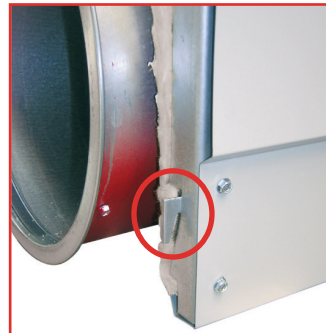

Reflector bayonet fixing

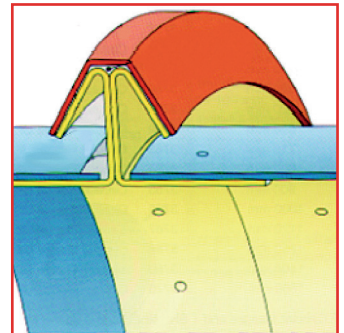

Conical securing ring detail

### Optional Condenser Module

The CD-003 & CD-004 is an optional module which is inserted into the Girad heating module flue system.

The flue products then pass through an internal heat exchanger fitted within the condenser module.

This heat exchanger extracts heat from the flue gasses and transfers it to water, which can then be used to serve a small water fed warm air heater.

The warm air heater can be used to heat a small workshop or room using free energy.

By using the Condenser module and utilising the otherwise wasted energy passing up the flue, the Girad system efficiency rises up to an impressive 107% (ncv).

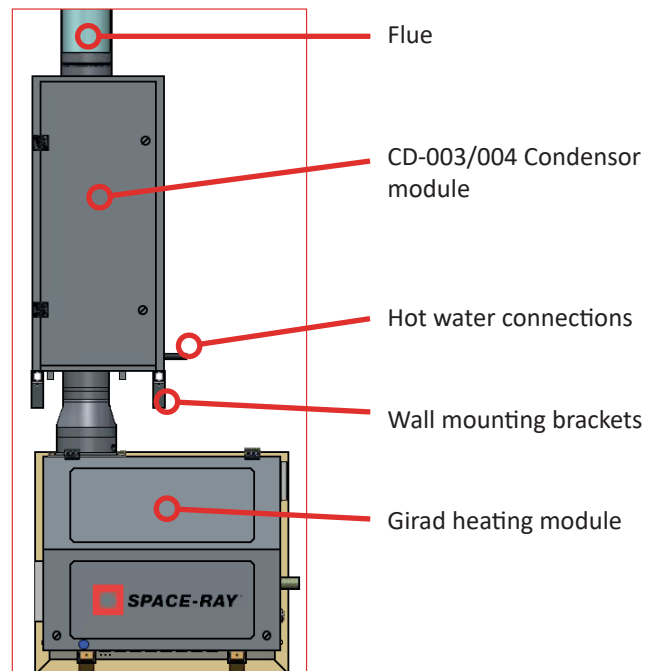

## Wall or Roof Mounted

The compact nature of the heating module enables it to be installed on either the roof or the wall, however wall installations tend to be most popular.

Wall installation versions are supplied with a fixing plate, which must only be fitted to a sturdy surface capable of supporting the weight of the heating module.

In applications where the wall is not sufficient to do this, then use of the additional support brackets (supplied) will be required.

Roof installation versions are supplied with a mounting plate, also included is an insulated section (which passes through the roof connecting the heating module to the radiant tubes.

Where installations require the heating module to be installed at a lower level, then the system will be supplied with sections of insulated tubes to connect the low level heating model to the high level radiant tubes.

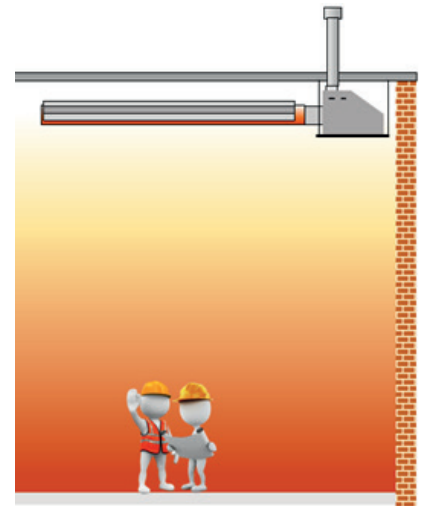
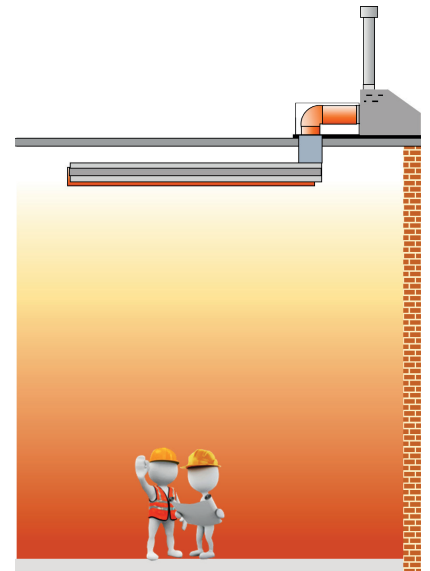
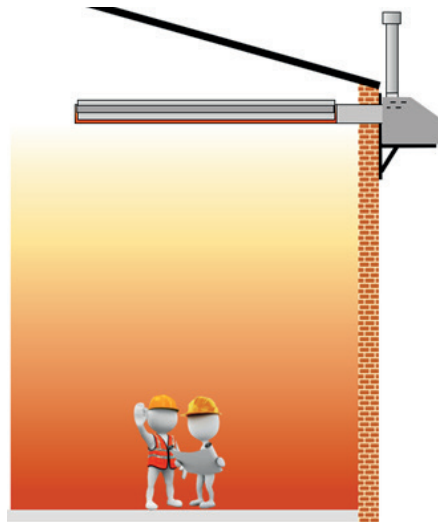
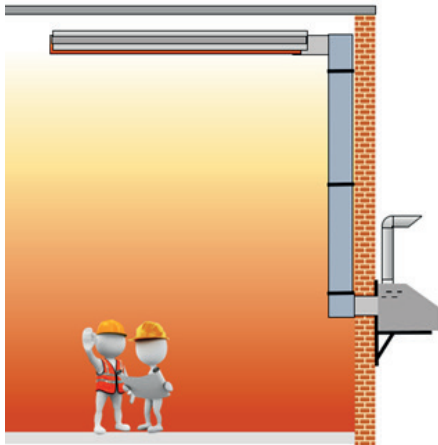

## Pre-assembled or Flat packed

Because not all installations are the same, we offer the option for the 'change of direction' sections to be supplied as an assembled module,

or supplied as loose components for self-assembly on site. Use of the pre-assembled module makes for a quicker and easier installation.

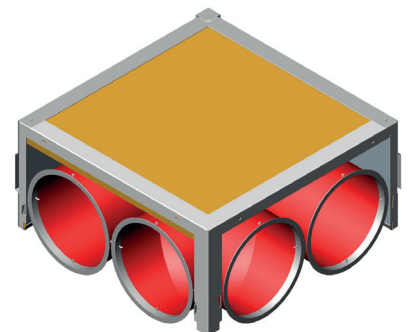
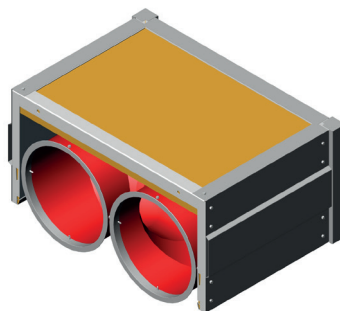
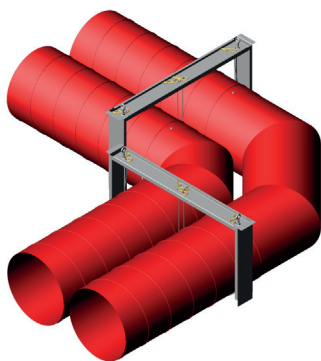
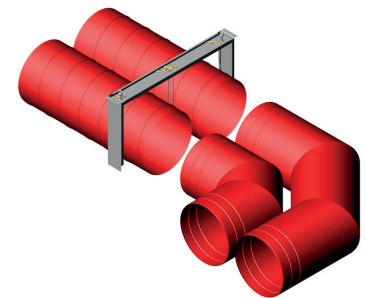

# Installation Flexibility

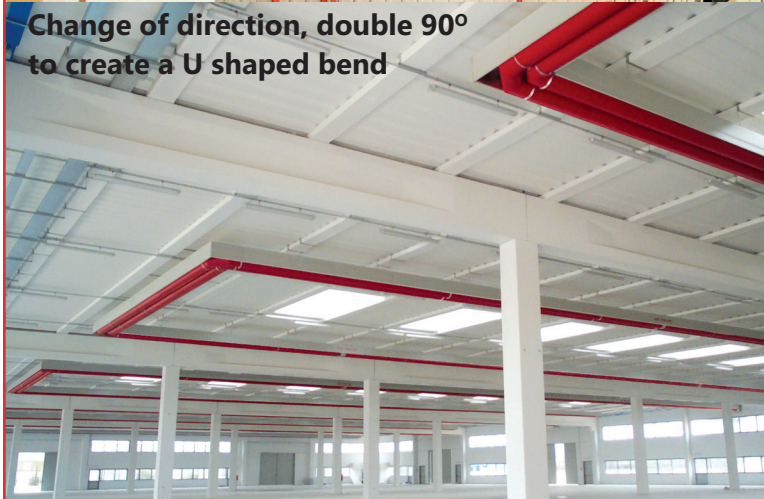
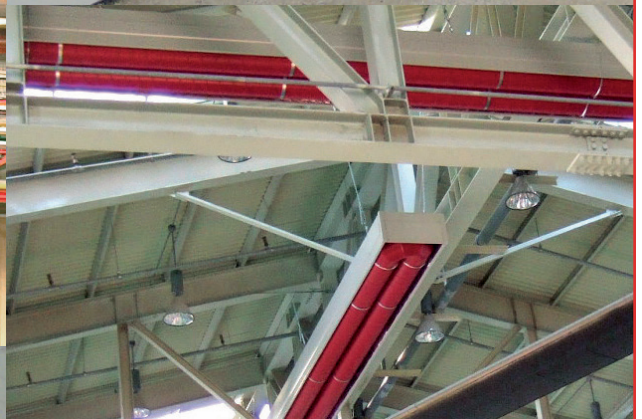

Change of direction can also be made as a 45° bend, either horizontal or vertically.

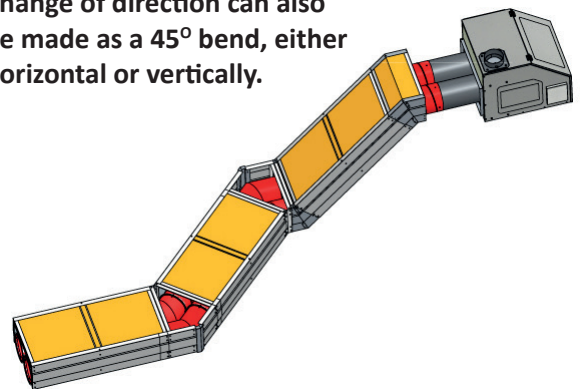

### SPECIFICATION GUIDE - GSR Range

Models		GSR50.1A GSR50.1H	GSR100.2H	GSR100.1A GSR100.1H	GSR100.1EA GSR100.1EH	GSR150A GSR150H	GSR200.1A GSR200.1H	GSR200.2H	GSR300.A GSR300.1H
Thermal Capacity	Maximum kW	50	100	100	115	150	200	200	300
	Minimum kW	35	70	70	90	120	140	140	210
Thermal efficiency <sup>1</sup>	% ncv	94 96	96	94 96	95 96	95 96	95 96	96	95 97
Gas connection	BSP	½"	¾"		1¼"				1½"
Oil connection	BSP	-		2 x ¾"	-			2 x ¾"	2 x ¾"
Maximum gas consumption	Nat Gas G20 m³/h	4.8	9.5	9.5	11.0	14.3	19.1	19.1	28.6
	LPG G30 kg/h	3.6	7.1	7.1	8.2	10.7	14.3	14.3	21.4
Flue connection OD	Ømm	104	144	144	144	144	205	205	250
Maximum oil consumption	l/h	-		10.34	-			20.67	31.01
Radiant tube diameter	mm	200			300				
Circuit length Ø200mm single pipe system <sup>2</sup>	Maximum m	72	90	-					
	Minimum m	42	54	-					
Circuit length Ø200mm twin pipe system <sup>2</sup>	Maximum m	36	45	-					
	Minimum m	21	27	-					
Circuit length Ø300mm single pipe system <sup>2</sup>	Maximum m	-		150	156	168	234	234	324
	Minimum m	-		54	60	76	102	102	156
Circuit length Ø300mm twin pipe system <sup>2</sup>	Maximum m	-		75	78	84	117	117	162
	Minimum m	-		27	30	38	51	50	78
Electrical supply		230V 1Ph N & E 50Hz						400V 3Ph N & E 50Hz	
Maximum electrical consumption	A	2.2	8.5	4.8	4.8	4.8	4.8	4.6	4.6
Burner module weight	kg	88	96	115	119	119	127	165	173
Max weight of radiant tube assembly Ø200mm per m	Single pipe system kg	16		-					
	Twin pipe system kg	19		-					
Max weight of radiant tube assembly Ø300mm per m	Single pipe system kg	-		18					
	Twin pipe system kg	-		25					

### SPECIFICATION GUIDE - GSR Range

Models		GSR100.2HC	GSR100.1HC	GSR100.1EHC	GSR150HC	GSR200.1HC	GSR200.2HC	GSR300.1HC	
Thermal Capacity	Maximum kW	100	100	115	150	200	200	300	
	Minimum kW	70	70	90	120	140	140	210	
Thermal efficiency <sup>1</sup>	% ncv	104.5							
Gas connection	BSP	¾"		1¼"				1½"	
Maximum gas consumption	Nat Gas G20 m³/h	9.5	9.5	11.0	14.3	19.1	19.1	28.8	
	LPG G30 kg/h	7.1	7.1	8.2	8.6	13.3	13.3	21.4	
Flue connection OD	Ømm	200							
Radiant tube diameter	mm	200	300						
Circuit length Ø200mm single pipe system <sup>2</sup>	Maximum m	90	-						
	Minimum m	54	-						
Circuit length Ø200mm twin pipe system <sup>2</sup>	Maximum m	45	-						
	Minimum m	27	-						
Circuit length Ø300mm single pipe system <sup>2</sup>	Maximum m	-	150	156	168	234	234	324	
	Minimum m	-	54	60	76	102	102	156	
Circuit length Ø300mm twin pipe system <sup>2</sup>	Maximum m	-	75	78	84	117	117	162	
	Minimum m	-	27	30	38	51	51	78	
Electrical supply		230V 1Ph N & E 50Hz					400V 3Ph N & E 50Hz		
Maximum electrical consumption	A	6	8.6				8.4		
Burner module weight	kg	191	210	214	214	257	280	303	
Max weight of radiant tube assembly Ø200mm per m	Single pipe system kg	16	-						
	Twin pipe system kg	19	-						
Max weight of radiant tube assembly Ø300mm per m	Single pipe system kg	-		18					
	Twin pipe system kg	-		25					

1. Based upon nett thermal efficiency (ncv); 2. Max length is based upon a straight run, length is reduced each time a change of direction occurs.

## Models GSR50.1, 100.1, 100.1E &150

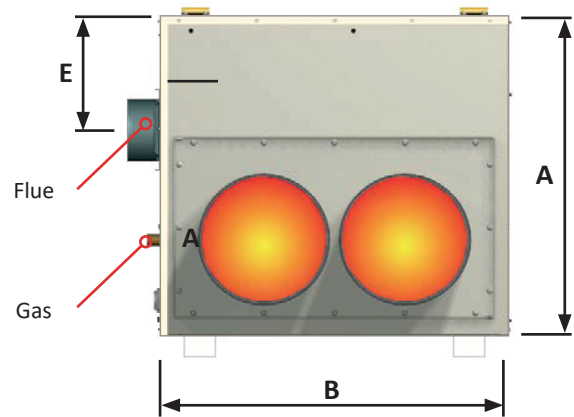
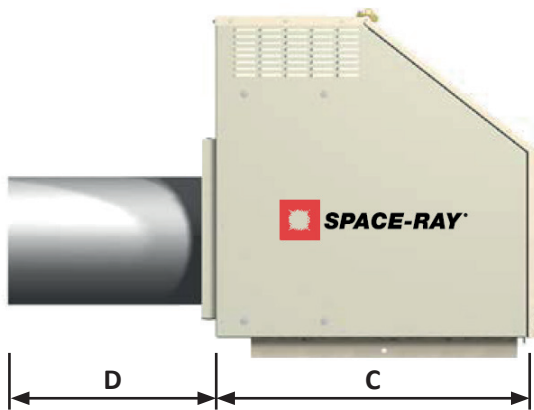

## Models GSR50.1, 100.1, 100.1E &150

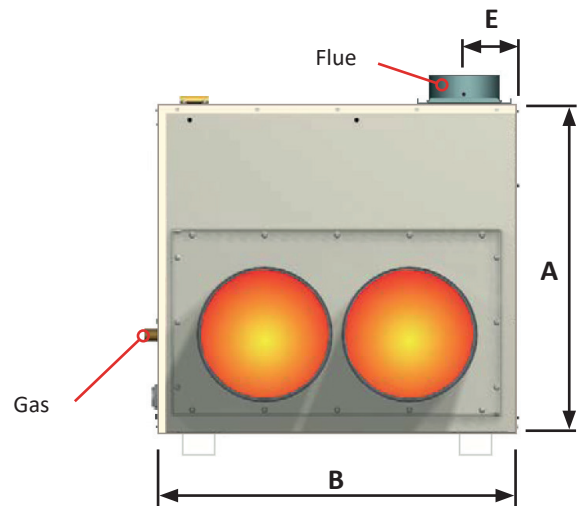
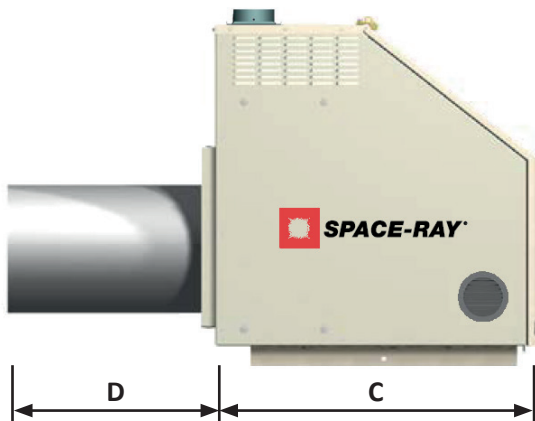

## Condenser Module CD-003 & 004

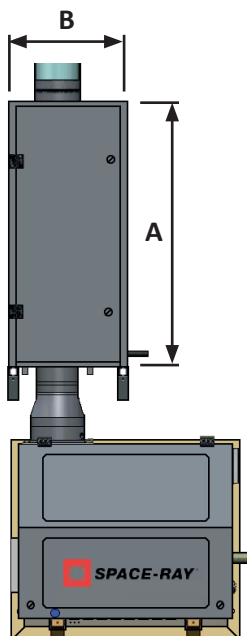

Burner Module & Condenser Dimensions					
Model	A	B	C	D	E
GSR50.1	744	742	810	438	248
GSR100.1 GSR100.1E GSR150	795	819	965	443	204
GSR100.2	744	745	810	438	148
GSR200.1	795	819	964	456	150
GSR200.2 GSR300.1	866	990	1012	456	179
CD-003	1003	550	597	-	-
CD-004	1236	550	602	-	-



**Gas Fired Products (UK) Ltd**  
Chapel Lane  
Claydon, Ipswich  
Suffolk, IP6 0JL  
Tel: +44(0)1473 830 551  
[www.spaceray.co.uk](http://www.spaceray.co.uk)  
[info@spaceray.co.uk](mailto:info@spaceray.co.uk)



**FACTORIES: IPSWICH, ENGLAND - CHARLOTTE, N.C, U.S.A**