

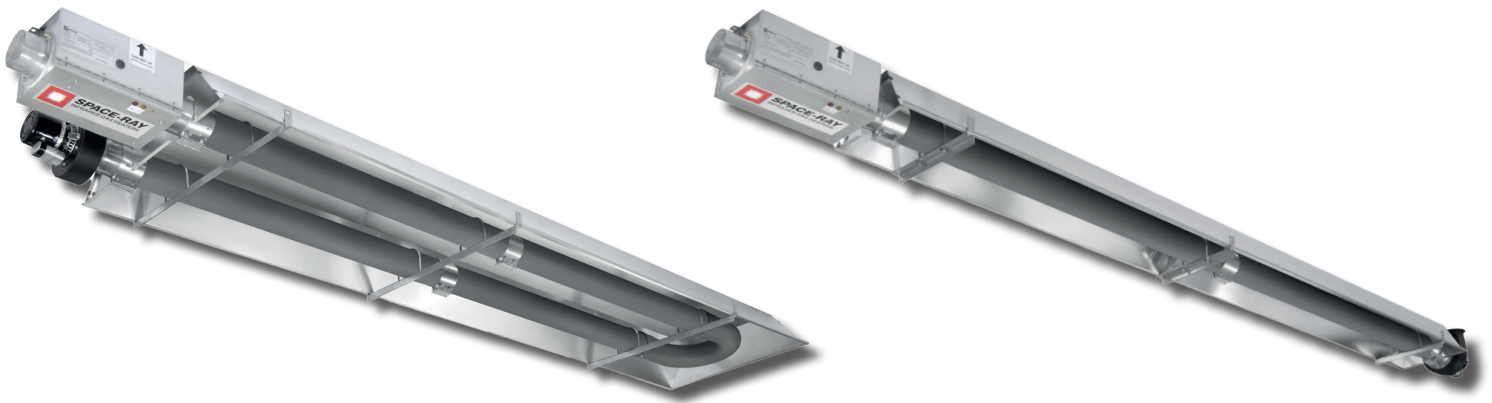

# LRU & LRL

## Gas Fired Radiant U Tube and Linear Heaters



*Innovation  
in design*



*Bespoke  
solutions  
made easy*

Find Your perfect Heating Solution

# LRU/LRL Radiant Tube Series

Gas Fired U Tube and Linear Models



- Six input ratings: 15kW to 47kW available in Linear and 'U' models
- 'Herringbone' link flue systems available with all 'U' and linear models
- Heat treated Aluminised Calorised emitter tube surface - for flake free and cleaner working environment
- Natural Gas and Propane
- Aluminium reflectors - the tested and proven superior material - designed to maximise downward radiant heating effect
- Lightweight construction - tubes supplied in 3m sections - easy to assemble and fit
- CE Approved
- Efficient and cost saving heating method
- Made in the UK under our ISO9001:2008 quality assured system - all units test fired before despatch

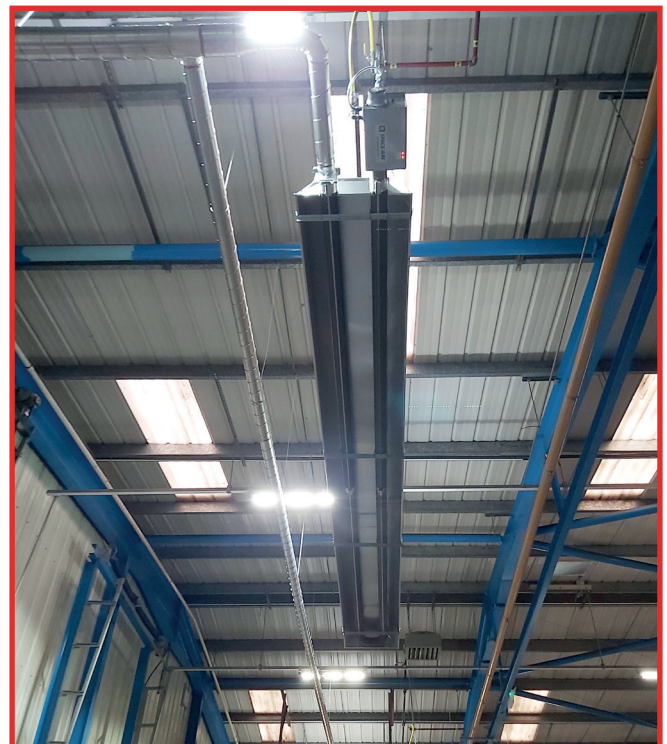

### SPECIFICATION GUIDE - LRU & LRL Series

Models		LRU15	LRU25	LRU30	LRU35	LRU40	LRU45	LRL15	LRL25	LRL30	LRL35	LRL40	LRL45
Heat Input	kW Hs	15.0	23.0	29.2	34.5	42.2	47.0	15.0	23.0	29.2	34.5	42.2	47.0
	kW Hi	13.5	20.7	26.3	31.1	38.0	42.3	13.5	20.7	26.3	31.1	38.0	42.3
Seasonal efficiency	ErP %	75.2	75.9	78.2	76.3	75.0	74.1	75.6	77.9	81.0	75.7	78.3	75.3
	BREEAM %	91.4	89.2	89.8	88.1	87.8	86.7	91.4	91.2	92.0	87.9	89.9	86.8
Gas connection	BSP	½"											
Maximum gas consumption	Nat gas G20 (m³/h)	1.43	2.38	2.86	3.34	3.81	4.29	1.43	2.38	2.86	3.34	3.81	4.29
	LPG G30 (kg/h)	1.08	1.80	2.15	2.51	2.87	3.23	1.08	1.80	2.15	2.51	2.87	3.23
Gas inlet pressure	mbar	Natural gas - 20mbar						LPG - 37mbar					
Flue connection	Ømm	127mm or 100mm											
Inlet air connection	Ømm	101mm											
Supply voltage	V	230V 50Hz 1PH N & E Current rating 0.55A External fuse rating - 3A											

### Dimensional Data

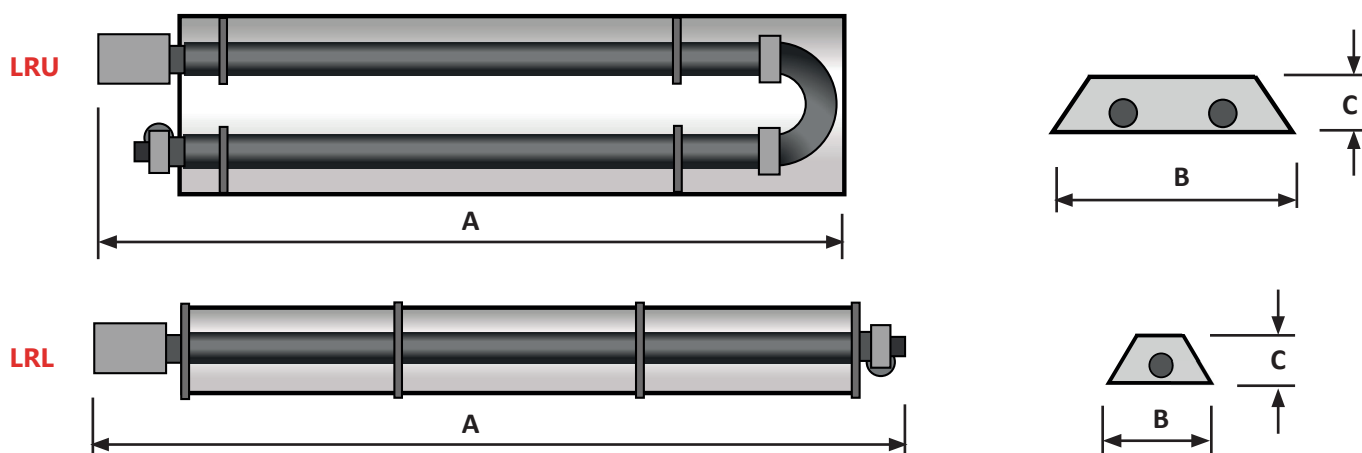

### DIMENSIONAL DATA - LRU & LRL Series

Models		LRU15	LRU25	LRU30	LRU35	LRU40	LRU45	LRL15	LRL25	LRL30	LRL35	LRL40	LRL45
Length (A) Standard unit	mm	3100	5385	5510		6970		5493	10065	9955		13000	
Length (A) Extended unit	mm	-		7034		8494		-		13003		16048	
Width (B)	mm	460		715				340					
Height (C)	mm	175		210				180					
Weight	kg	31	47	66-std 81-ext		81-std 96-ext		27	46	62-std 79-ext		79-std 96-ext	

### RECOMMENDED MOUNTING HEIGHT RANGE (General Guidance only) - LRU & LRL Series

Models		LRU & LRL15	LRU & LRL25	LRU & LRL30	LRU & LRL35	LRU & LRL40	LRU & LRL45
Horizontal mounting	m	2.4 to 6.0	3.0 to 8.0	3.8 to 10.0	4.0 to 12.5	4.8 to 13.5	5.6 to 15.0
Angled mounting >30°	m	2.1 to 4.5	2.7 to 5.0	3.3 to 7.0	3.7 to 8.0	4.0 to 9.0	4.8 to 11.0

### Clearances To Combustibles

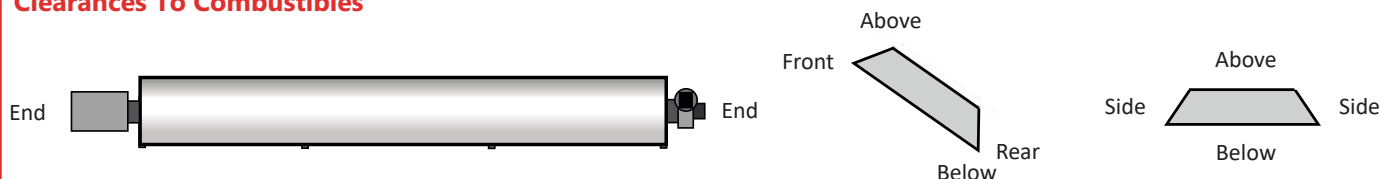

### MINIMUM CLEARANCES TO COMBUSTIBLE SURFACES - LRU & LRL Series

Models	Side	Above	Below	End	Front	Rear
LRU & LRL15 to 25	510mm	450mm	1220mm	510mm	610mm	305mm
LRU & LRL30 to 45	760mm	610mm	2285mm	610mm	760mm	380mm



*Tel: +44(0)1473 830 551*

*Fax: +44(0)1473 832055*

*www.spaceray.co.uk*

*info@spaceray.co.uk*



Gas Fired Products (UK) Ltd  
Chapel Lane  
Claydon  
Ipswich  
Suffolk, IP6 0JL



**FACTORIES: IPSWICH, ENGLAND - CHARLOTTE, N.C, U.S.A**